

 **BALL-SCREW PRESS BRAKE**
Compact Bending Solutions with High Efficiency



* Machine with optional equipment



BALL-SCREW PRESS BRAKE

Single / Dual Lenze drive technology

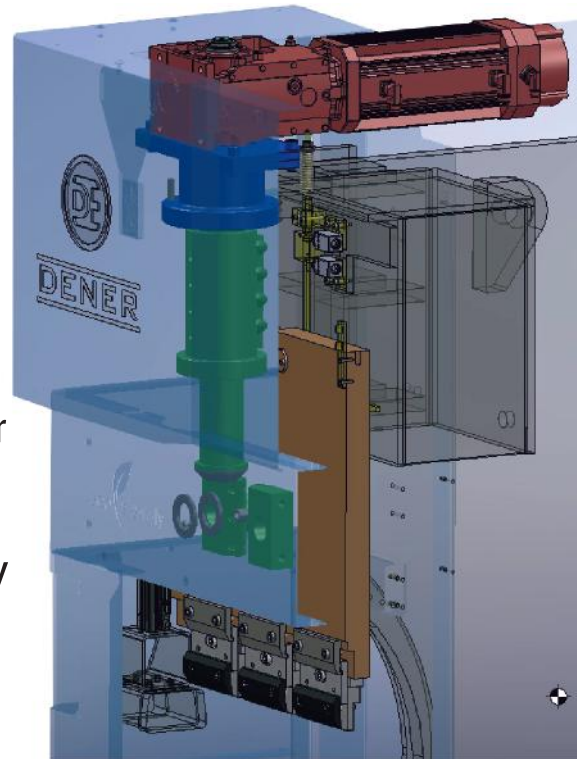

Energy saving up to 50%



High speed bending produces more parts per hour



Low maintenance cost



High accuracy positioning and repeatability



Light and compact design

Control Unit

ESA S 630 Control Unit

- 10" color touch screen
- Automatic bend sequence
- Easy programmable 2D graphic display.
- Up to 4 axes (Y1,Y2, X and R)
- Multiple language options
- 2D Simulation
- Remote access

ESA 675 W 3D Control Unit (Optional)



Work Table (Optional)

Foldable and height adjustable ergonomic working table makes bending easier and comfortable.



Clamping & Tools

Euro Type punch and die clamping systems.

Wila mechanical and hydraulic clamping system (Optional)

Euro punch holder with high precision double wedge adjustment.(Optional)

Punch and die is optional.





DDS 4013



DDS 2090



DDS 2060

Back Gauge

- 2 axis back gauge handles complex parts with ease. (5 axis optional - Z1, Z2 and X-Prime with ESA675 controller)
- High speed movement combined with high accuracy drives ensures the back gauge is positioned quickly and precisely every time for the operator.

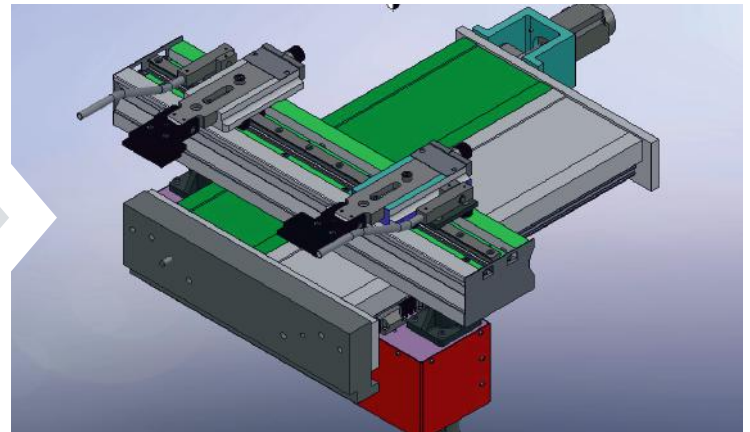

Safety System

Front laser finger protection system with safety DSP AP (Optional).



Other Advantages

- Electrical cabinet cooler
- Easier box bending with larger open height
- Quick installation and transportation

Body Frame

Solid mono-block body with small C frame gap provides high precision bends.

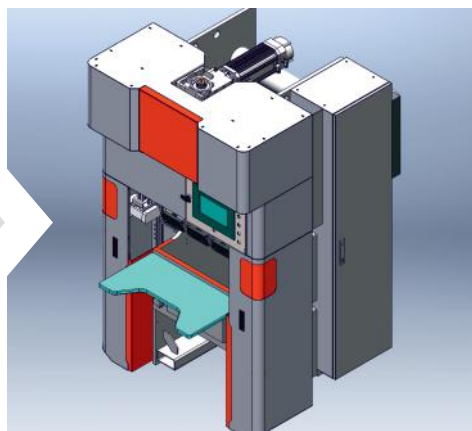

NO | HYDRAULIC OIL CYLINDERS

Technical Data

	DDS 4013	DDS 2090	DDS 2060
Bending Length (B) (mm)	1300	900	600
Bending Capacity (ton)	40	20	20
Daylight (Q) (mm)	375	375	375
Maximum Stroke (mm)	150	150	150
Y Axis (Approaching/Bending/Return) Velocity (mm/sec)	150/20/150	150/20/150	150/20/150
Motor Power (kW)	2x3,8	3,8	3,8
Lenght (A) (mm)	1880	1280	1280
Width (C) (mm)	2435	1760	1410
Height (D) (mm)	2320	2190	2190
Weight (Appr.) (kgs)	3400	2000	1700

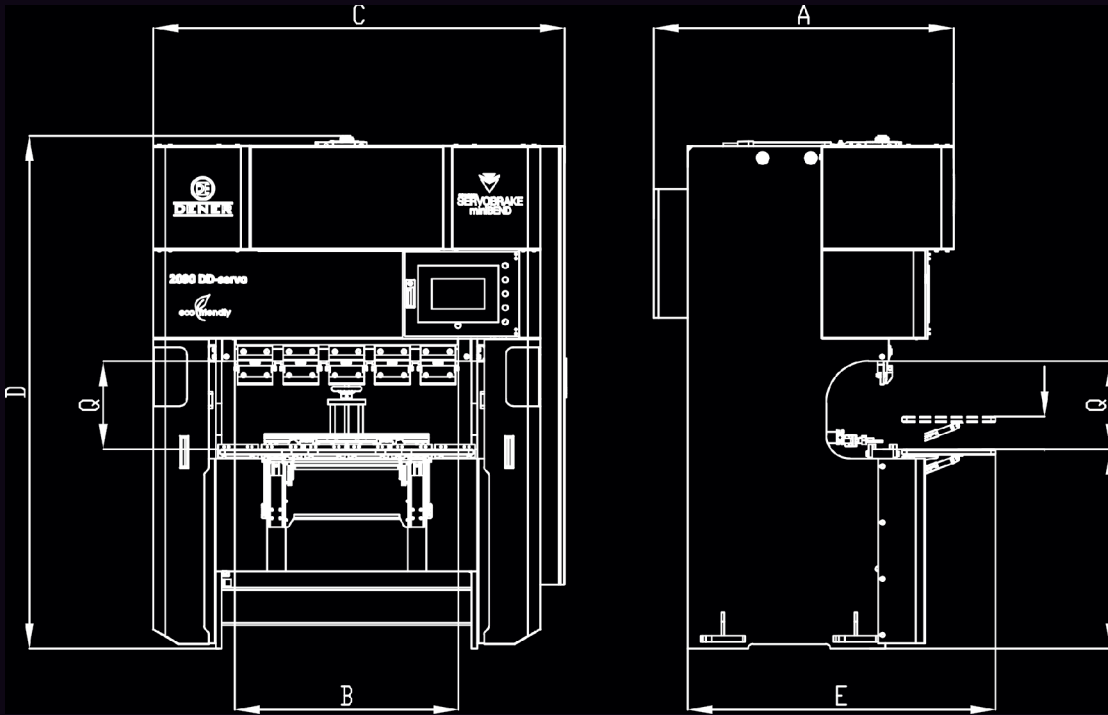

Organize Sanayi Bölgesi
8.Cadde No:40-42 38070
Melikgazi / Kayseri / TÜRKİYE



+90 352 321 13 50

+90 352 321 13 53

info@dener.com

www.dener.com